

Mobile Thermal Printer

210A USER MANUAL

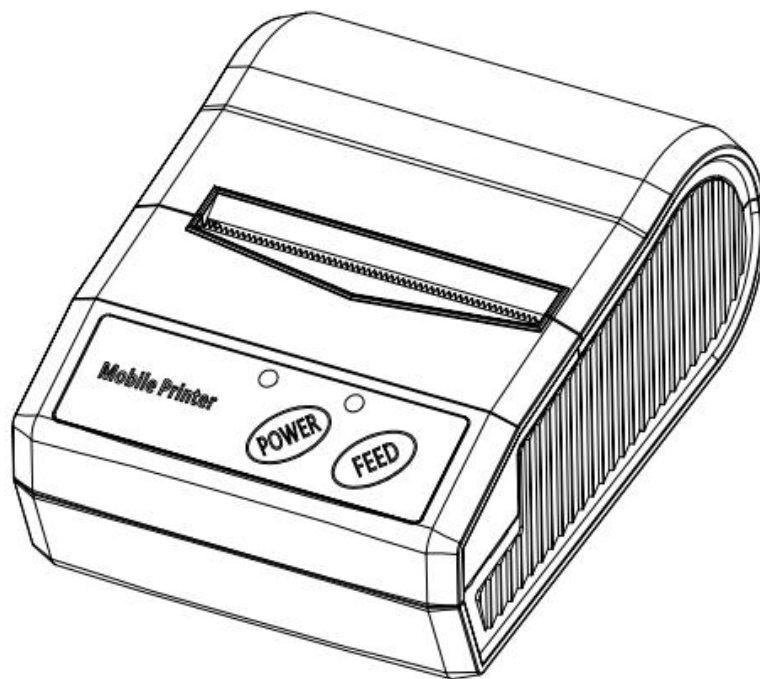

Contents

I. NOTICE.....	2
1.1 SAFETY NOTICE.....	2
1.2 USAGE NOTICE.....	2
1.3 STORAGE NOTICE.....	3
1.4 BATTERY SAFETY NOTICE.....	3
II. INTRODUCTION.....	5
2.1 PRINTER OUTER DESIGN.....	5
2.2 ACCESSORIES.....	6
III. PERFORMANCE.....	6
3.1 PRINT PERFORMANCE.....	6
3.2 PHYSICS PARAMETER.....	7
3.3 ENVIRONMENT PARAMETER.....	7
3.4 OTHER PERFORMANCE.....	7
IV. INTRODUCTION.....	8
4.1 PREPARING BEFORE USAGE.....	8
4.1.1 Battery Installation.....	8
4.1.2 Paper Roll Installation.....	9
4.2 BASIC FUNCTION.....	9
4.2.1 Power On.....	9
4.2.2 Power Off.....	9
4.2.3 Self-Test.....	10
4.2.4 Feed (Feed Manually).....	10
4.2.5 Charge.....	10
4.3 PRINTER CONNECTING AND PRINTING.....	10
4.3.1 USB Interface Connecting.....	10
4.3.2 The Bluetooth Matching and Printing.....	11
4.4 INDICATOR LIGHT AND BUZZER SIGNAL DESCRIPTION.....	11

Note: This equipment has been tested and found to comply with the limits for a Class B digital device, pursuant to Part 15 of the FCC Rules. These limits are designed to provide reasonable protection against harmful interference in a residential installation. This equipment generates, uses, and can radiate radio frequency energy, and if not installed and used in accordance with the instructions, may cause harmful interference to radio communications. However, there is no guarantee that interference will not occur in a particular installation. If this equipment does cause harmful interference to radio or television reception, which can be determined by turning the equipment off and on, the user is encouraged to try to correct the interference by one or more of the following measures:

- Reorient or relocate the receiving antenna.
- Increase the separation between the equipment and receiver.
- Connect the equipment into an outlet on a circuit different from that to which the receiver is connected.
- Consult the dealer or an experienced radio/TV technician for help.

changes or modifications not expressly approved by the party responsible for compliance could void the user's authority to operate the equipment.

This device complies with Part 15 of the FCC Rules. Operation is subject to the following two conditions:

- (1) this device may not cause harmful interference, and
- (2) this device must accept any interference received, including interference that may cause undesired operation.

This equipment complies with FCC radiation exposure limits set forth for an uncontrolled environment. This equipment should be installed and operated with a minimum distance of 20cm between the radiator & your body. This transmitter must not be co-located or operating in conjunction with any other antenna or transmitter.

I. Notice

Please read the following information carefully before using the printer!

1.1 Safety Notice

This printer can only use battery and power adapter provided by our company, or it may cause damage to the printer, battery leakage, fire or explosion.

Do not put the battery into the fire, not make it short circuit, break up or heating, otherwise it may cause the battery leakage, fire or explosion.

The battery liquid is corrosive, if the user's careless operation leads the battery leakage and the liquid viscosity to the skin or the clothes please use the clean water for washing immediately, if accidentally into the eyes, please rinse with plenty of clean water to wash the eyes then goes to the hospital.

Do not open paper cover and use hand or any part of body to touch the printer mechanism when printing or printing just end, to avoid the exorbitant temperature causes scald.

Do not use the printer when the operation is failed because that would cause a fire or electric shock. Please turn off and unplug it, then call the dealer.

1.2 Usage Notice

The printer can not be immersed into the water and not be exposed in the rain for a long time; otherwise it may lead the damage to the printer.

Do not open the paper cover when printing or it may cause the printer working improperly.

If use the serial interface to print, do not pull off the serial line when printing, otherwise it may result in incompleteness of the final print data.

When using IR to print, the user should aim the IR windows of main equipment at the IR windows of printer, the distance between them should be not more than 50 centimeters, and the angle should not exceed 30 degrees, or it may lead to print garbled or unable to print.

The printer could work stably from -10°C to 50°C , but the higher temperature ($\geq 45^{\circ}\text{C}$) or lower temperature ($\leq -5^{\circ}\text{C}$) would debase the print quality.

Higher humidity ($\geq 85\%$) or lower humidity ($\leq 20\%$) also may debase the print quality.

Use the bad print paper or long time storage paper would affect the print quality, even damage the printer.

When the printer is working in black mark detection mode (when printing the pre-print receipt with black mark), it requires the black mark that on the pre-print paper is accord with black mark printing standard (as details in 4.2 Pre-print Black Mark Instruction), otherwise it may lead the printer disable to detect the black mark accurately.

The battery of the printer is better running out before charging, which could effectively ensure the lifespan of it.

1.3 Storage Notice

The printer should be stored in the environment where the temperature is -20°C to 70°C and relative humidity is 5% to 95%.

If the user plan to store the printer for a long time, please be sure to take out the battery and stored it separately, or it may result in the battery lose efficacy, even leakage and then damage the printer.

The storage time of common thermal paper is short, if the user need to print the long-term preservation receipt, please use long-acting thermal paper.

Do not store the thermal paper in a high temperature or direct sunlight environment, if it has been sealed off, please store it in dark place.

1.4 Battery Safety Notice

Please read this user manual carefully before using the printer. Ignoring the followings may cause overheating, burning, explosion, damage of the battery and/or debase the lifespan of the printer.

Warning:

1. Do not let water or sea water in or leak into the battery. If the safety device in it is burned out, any charge of it would lead abnormity current and/ or voltage and bring unusual chemistry reaction, then cause the overheating, burning and/ or explosion of it.

2. Do not use or place the battery near burner or high temperature environment. Overheating may cause the damage to the resin shell and/or heat insulation material, and bring the short circuit in the battery then lead the overheating, burning and/ or explosion of it.

3. Please use dedicated charger when charging. When charging under the excluded conditions (such as high temperature, high voltage/current or using modified charger) may cause excessive battery charging, abnormal current and/ or voltage, bring unusual chemistry reaction and then may result in overheating, burning and or explosion of it.

4. Positive and negative poles are marked clearly on the battery. The user should make sure the battery position is correct when inserting it in the charger or product. Reverse insertion would lead reverse charging, may bring unusual chemistry reaction and then cause overheating, burning and/or explosion of the battery.

5. Do not make the battery contact to power socket and/or car cigarette lighting socket, which may lead high voltage, bring excessive current and result in overheating, burning and/or explosion of it.

6. Do not heat the battery or put it into the fire that may melt the heat insulation material and/or damage the safety device or equipment and make the electrolytic ignited, then bring overheating, burning and/or explosion of it.

7. Do not take the opposite position ((+) and (-)) when using battery. During the charging process, it would cause reverse charge and bring unusual chemistry reaction. During the using process, it may bring unpredictable current abnormality, then cause overheating, burning and/or explosion of it.

8. Do not make the battery poles ((+) and (-)) contact to any metal. In addition, do not take or store it with metal materials, such as necklace, hairpin etc. Short circuit in the battery may cause excessive current, then bring overheating, burning and/or explosion of it and overheating of neighboring metal materials.

9. Do not throw the battery or make it damaged. If the safety device in it is burned out, any charging of it would bring abnormal current and/or voltage, bring

unusual chemistry reaction, then may lead to overheating, burning and/or explosion of it.

II. Introduction

2.1 Printer outer design

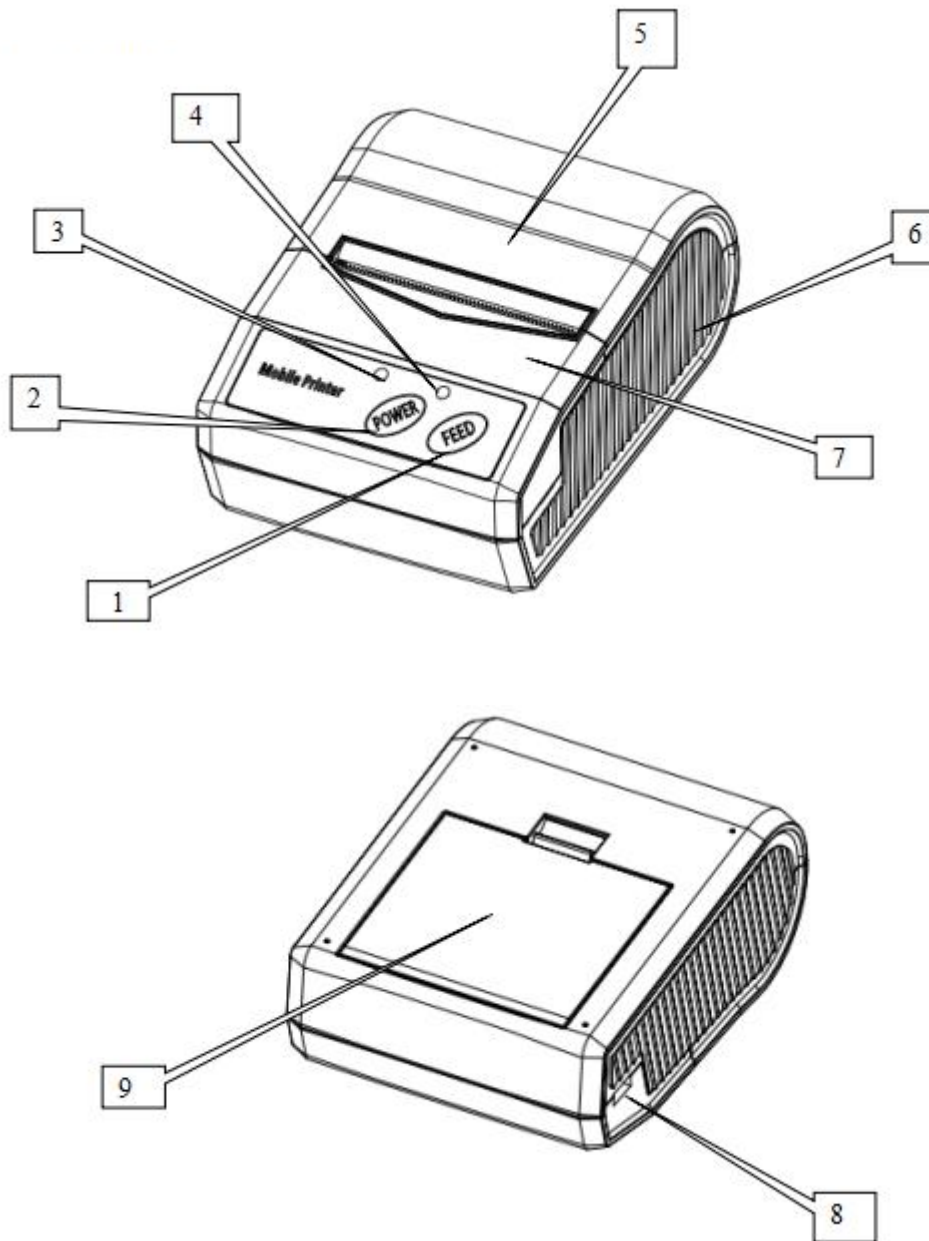



1. Feed Key
2. Power Key

-
3. Charge Indicator
 4. Status Indicator
 5. Printer Top Cover
 6. Body
 7. Printer front Cover
 8. USB Interface
 9. Battery Cover

2.2 Accessories

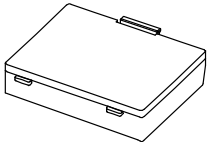
Standard Accessories

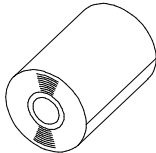
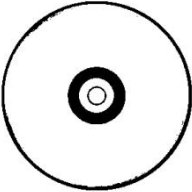
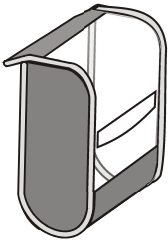
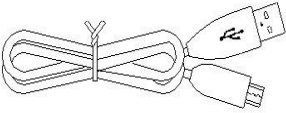
<p>Battery</p> 	<p>Power Charger</p> 	<p>Paper Roll</p> 
<p>CD-ROM</p> 	<p>Leather Sheath</p> 	<p>USB Data Wire</p> 

III. Performance

3.1 Print Performance

Printing way: Direct thermal print

Paper width: 58mm

Printing width: 48mm

Resolution: 8dots/mm (203dpi)

Dot/line: 384dots

Printing speed: 60mm/s

Paper thickness: 60-80 μ m

Printing Content: Chinese (Support all GB18030 Chinese character, character sets), ASCII character, some full width custom characters and some half width custom characters; barcode: CODE39, EAN13, EAN8, CODABAR, CODE93, ITF; graphics.

3.2 Physics Parameter

Outer dimension: 103x78x46mm

Gross weight: 246g (Include the paper roll)

Scroll Diameter: \leq 40mm

Interface: USB, Bluetooth

3.3 Environment Parameter

Working temperature: -10 $^{\circ}$ C \sim 50 $^{\circ}$ C

Working humidity: 20% \sim 85%

Storing temperature: -20 $^{\circ}$ C \sim 70 $^{\circ}$ C

Storing humidity: 5% \sim 95%

3.4 Other Performance

Paper loading way: Clamshell paper loading(as details 4.1.2 Paper Roll Installation);

Paper sensor: Power and function indicator of printer flashes when come to paper end meanwhile alarm;

Printing Command: ESC/POS compatible with commands set (see “210 Command Set”), the user could get it from the supplier;

Power: 1600 mAH rechargeable li-ion battery

Adapter to recharge: battery can be filled with in 3 hours .

Notice: The battery to recharge can't use Adapter and USB at the same time.

A charging time available: Normally, the battery could be used for printing 185meters or 3 hours. The parameter is only for reference; the capacity of the battery would be decreased after a long time using and could not ensure the actual print time.

IV. Introduction

4.1 Preparing before usage

4.1.1 Battery Installation



1. Pull up the buckle, open battery cover;
2. As shown in the picture, put battery into the battery compartment. Please do not put the negative and positive poles of battery in wrong way;
3. Then closed the battery cover.

4.1.2 Paper Roll Installation



Usage Method:

1. Using two hands to keep pressing the cover then open it.
2. As shown in picture, please put the paper roll in and do not put it in wrong direction, otherwise it would lead the printer unable to work.
3. As shown in picture, pull out part of paper; please make sure to pull the paper out of the paper roll compartment.
4. Put the paper roll in the right way and then close the cover.

4.2 Basic Function

4.2.1 Power On

Under power off status, keep pressing "POWER" key for two seconds, printer will be powered on and on working status, then power indicator (red light) lights.

Note: If printer feed indicator (blue light) flashes but not lack of paper, it means the printer is going to power off, please change the battery or charge it. Charging method please refer to (4.2.5 charging).

4.2.2 Power Off

Under power on status, keep pressing "POWER" key for two seconds, then the printer will be powered off and all indicator lights will be put out.

4.2.3 Self-Test

Once the user receives the printer could do the self-test at any time to check the setting and status of it.

Self-Test method as follows: Power off(If the printer is power on)the printer, press "FEED" key and at the same time press "POWER" key to power on it, then the printer will print out the self-test page, which contains the printer status, setting and printing sample.

4.2.4 Feed (Feed Manually)

Under printer working status, press "FEED" key, the printer will start feeding paper for 250mm length. If the paper has black mark accepted by the printer, the printer will stop feeding when goes to the black mark. If feeding length is set as "0", printer feeding will not be affected by black mark.

4.2.5 Charge

When the printer has been working for a long time, the battery will be out of power, in this case, the printer feed indicator (blue light) will flash, which means it needs charging. If the printer power off automatically while printing, the user should charge it for continue working.

Charging method as follows: The printer is charging after plugging the charger into 220V, 50HZ power socket, and the other end plug to the charger socket of the printer. During the charging process, under power on status, feed indicator (blue light) will keep flashing till the charging is finished and the feed indicator (blue light) is keep lighting.

Printer can work normally during charging process.

4.3 Printer Connecting and Printing

4.3.1 USB Interface Connecting

Printer's optional accessories contain USB Wire, Connect to PC and install the USB driver

4.3.2 The Bluetooth Matching and Printing

Before working, 210 series/BL portable mini printer need to be matched with primary device, which will drive 210 series/BL printer, the matching will be started by primary device.

Matching Method as follows:

1. Power on Printer
2. Primary Device search for external Bluetooth devices
3. If there are more than one external Bluetooth devices, select the printer which is corresponding to the BDA address (refer to self-test page).
4. Input password"0000"
5. Finishing Matching.

About matching method details, please refer to primary Bluetooth function description.

During matching, 210 series/BL portable mini printer must be power on.

Note: During matching, don't power on more than one unit printer, otherwise, the user may not know which printer will be matched successfully.

After matching successfully, other PC still can be matched with the printer, each printer can be at most matched with eight PC, if matched with more than eight PC, the printer that earliest be matched with PC will be deleted automatically, at this time, if this printer need the PC to drive it, then it need to be re-matched with PC.

Using Bluetooth Interface to Print

For the PC with virtual Bluetooth serial port (such as cell phone using the SMARTPHONE, POCKET PC, PALM, laptops, etc.), after the success of the matching, you can send printing data through virtual Bluetooth serial port to the 210 series/BL portable mini printer for printing. If the PC doesn't have virtual Bluetooth serial port, and you want to drive the 210 series/BL portable mini printer, please consult your PC supplier.

4. 4 Indicator Light and Buzzer Signal Description

Printer has a buzzer and two indicators light that used to prompt the user the status of the printer, the light is used to represent the current status of the printer, and

buzzer used to prompt the printer status changes. Two indicator lights are respectively function indicator light and charge indicator.

Feed Indicator(blue)	Paper	Power Indicator (red)	Printing Status	Buzzer
Quick flashing		Long lighting	Charging	
Slow flashing		Long lighting	Low level	
Long lighting		Long lighting	Finish charging	
No flash		Long Lighting	Power on Status	With a buzz
Slow flashing		Slow Flashing	Lack of paper	
No flash		Slow Flashing	Sleep status	